

**Nikon**  
EL-Nikkor **50mm f/2.8N**



**Enlarging Lens**

**INSTRUCTION MANUAL**

**Nikon** NIPPON KOGAKU K.K. Tokyo, Japan

## Foreword

The EL-Nikkor 50mm f/2.8N is an improved version of the famous EL-Nikkor enlarging lens of the same focal length and maximum aperture. Its wide maximum aperture of f/2.8 produces bright and easy-to-focus images even when you are enlarging dense negatives. It also features transilluminated f-numbers and an adjustable f/stop window for convenience while working in the darkroom. Keep this instruction manual on hand for ready reference until you have mastered the operation of this piece of equipment.

## Mounting the lens

This EL-Nikkor utilizes the 39mm screw mount ( $P = 1/26''$ ), so it can be used with virtually any enlarger. Grasp the mounting ring and screw the lens clockwise until it doesn't move anymore; otherwise the lens will not be firmly seated. To position the f/stop window in front, rotate the mounting ring (f/stop centering ring) counterclockwise until the window is where you want it. Click stops are provided at  $30^\circ$  intervals. Be sure to set the ring to a click stop; otherwise, the f/stop window may shift while you're changing the aperture.

## Removing the lens

To remove the lens from the enlarger, hold the mounting ring and turn it counterclockwise. As it is turned, you'll feel click stops. After the last stop, apply a little more force to loosen the lens completely. Then continue turning until the lens comes off.

### Nomenclature

Name Ring

Front lens element

Aperture index

f/stop scale

Mounting ring  
(f/stop centering ring)

Aperture ring

f/stop window

Rear lens element

39mm screw mount

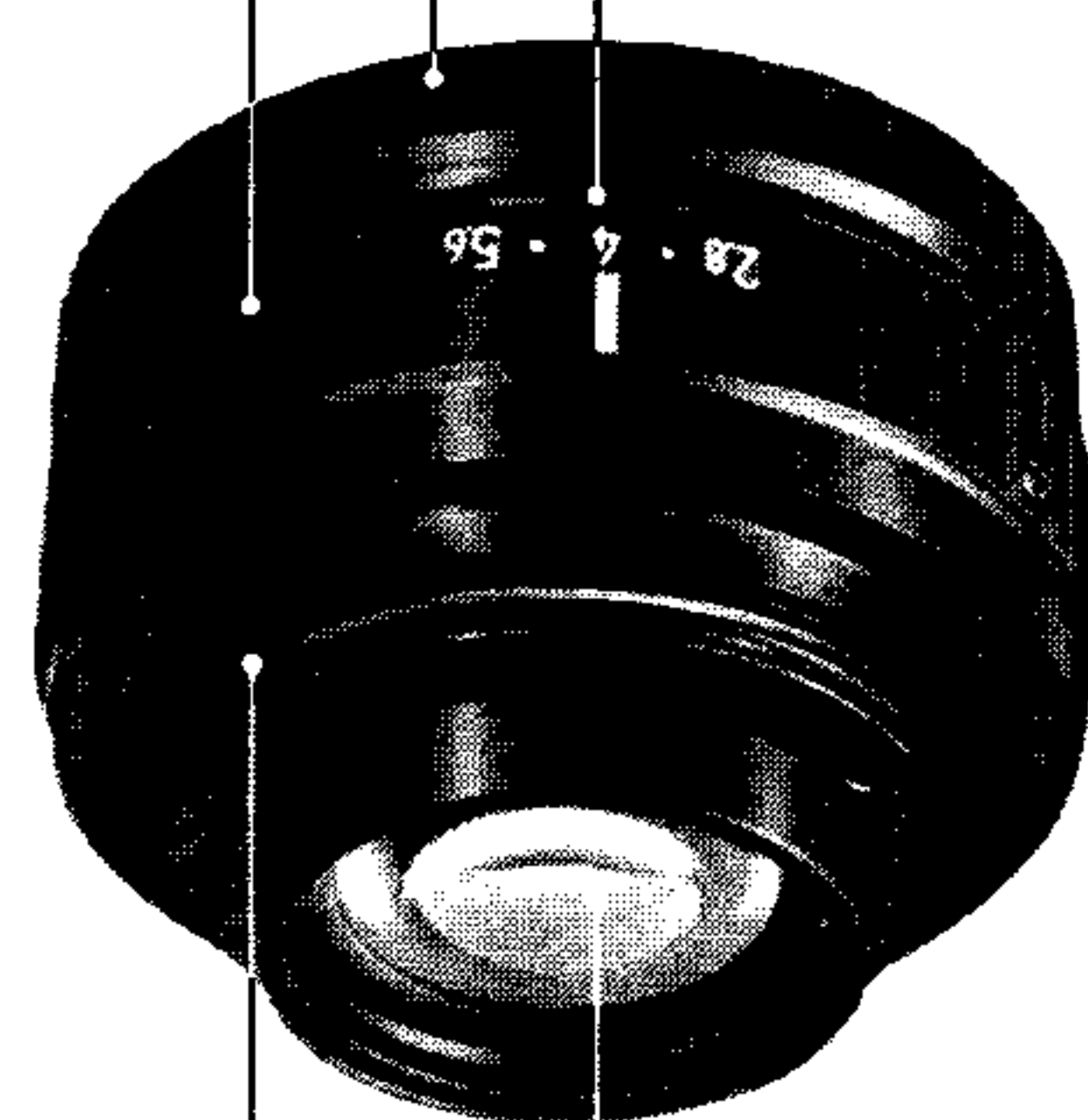
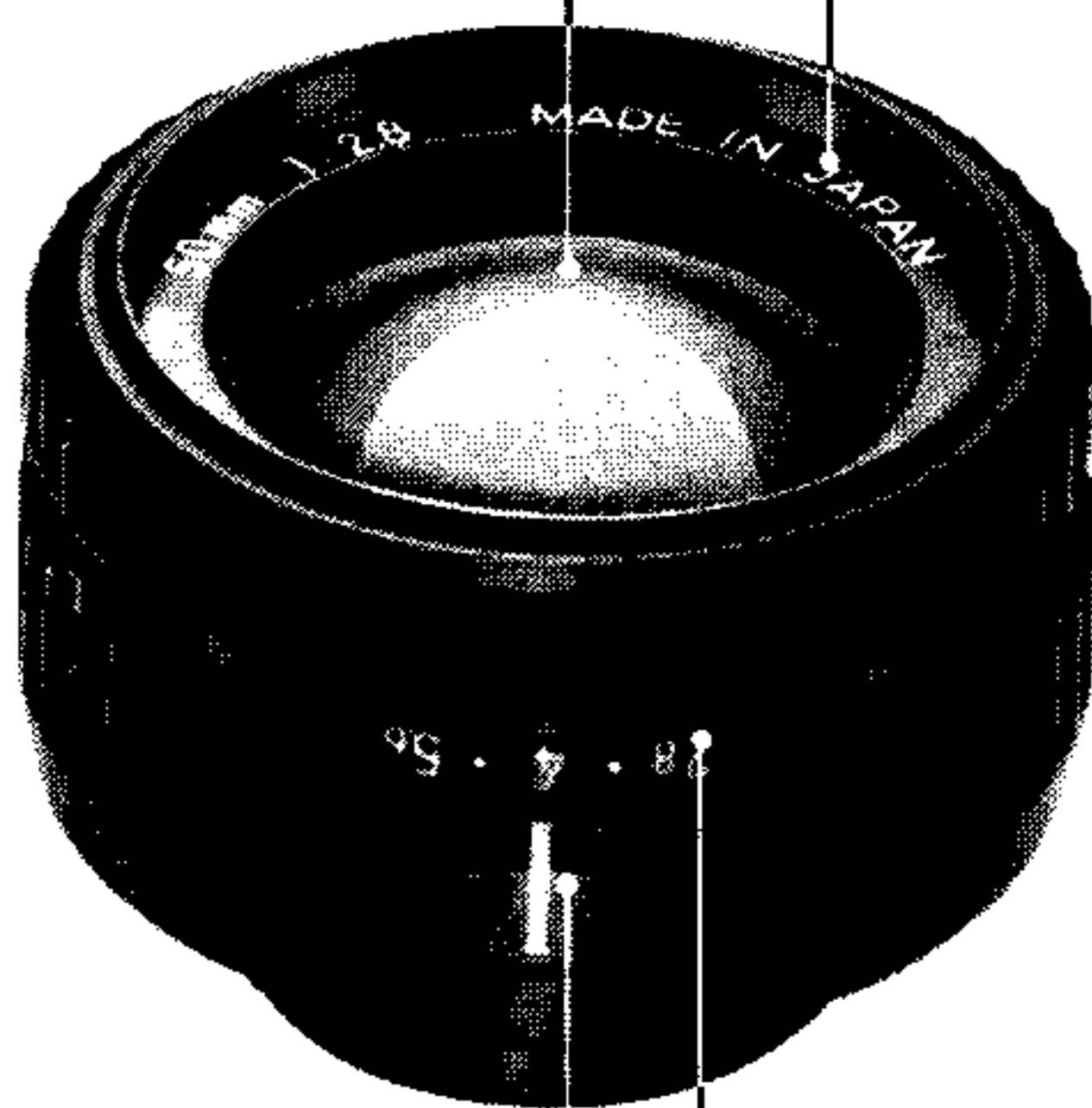

**For enlargers having a slide-in lens board**

Because of its protruding rear lens element, the EL-Nikkor 50mm f/2.8N may require the use of the optional 15mm EL-Extension Ring. First, screw the extension ring into the back of the lens. Then, screw the ring, plus lens, into the enlarger's lens board. (See Fig. 1) However, please realize that the use of an extension ring may limit the enlarger's capability of making really big enlargements.

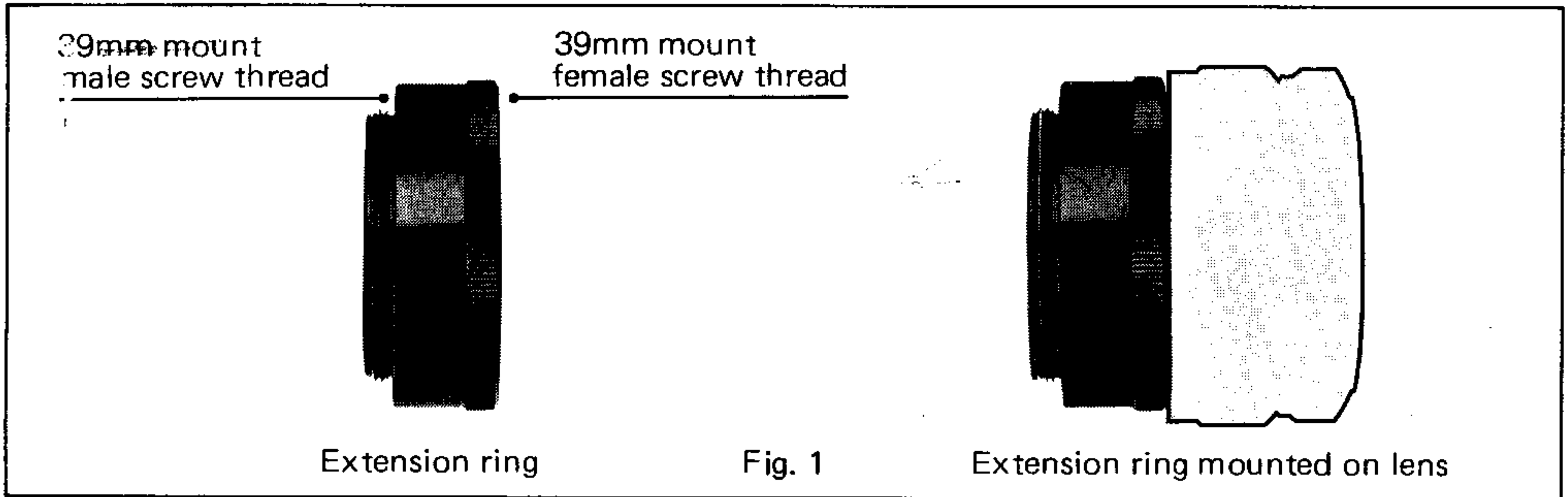

**Mounting the lens in reverse position**

To mount the EL-Nikkor lens to a process camera or to make reductions instead of enlargements with your enlarger, you can use the optional Reversing Adapter to mount the lens in the reverse position. First, screw the adapter ring into the front of the lens; then mount the ring, plus lens, to the camera or enlarger. When the lens is mounted in the reverse position, the f/stops are no longer illuminated nor is it possible to adjust the f/stop window. (See Fig. 2)

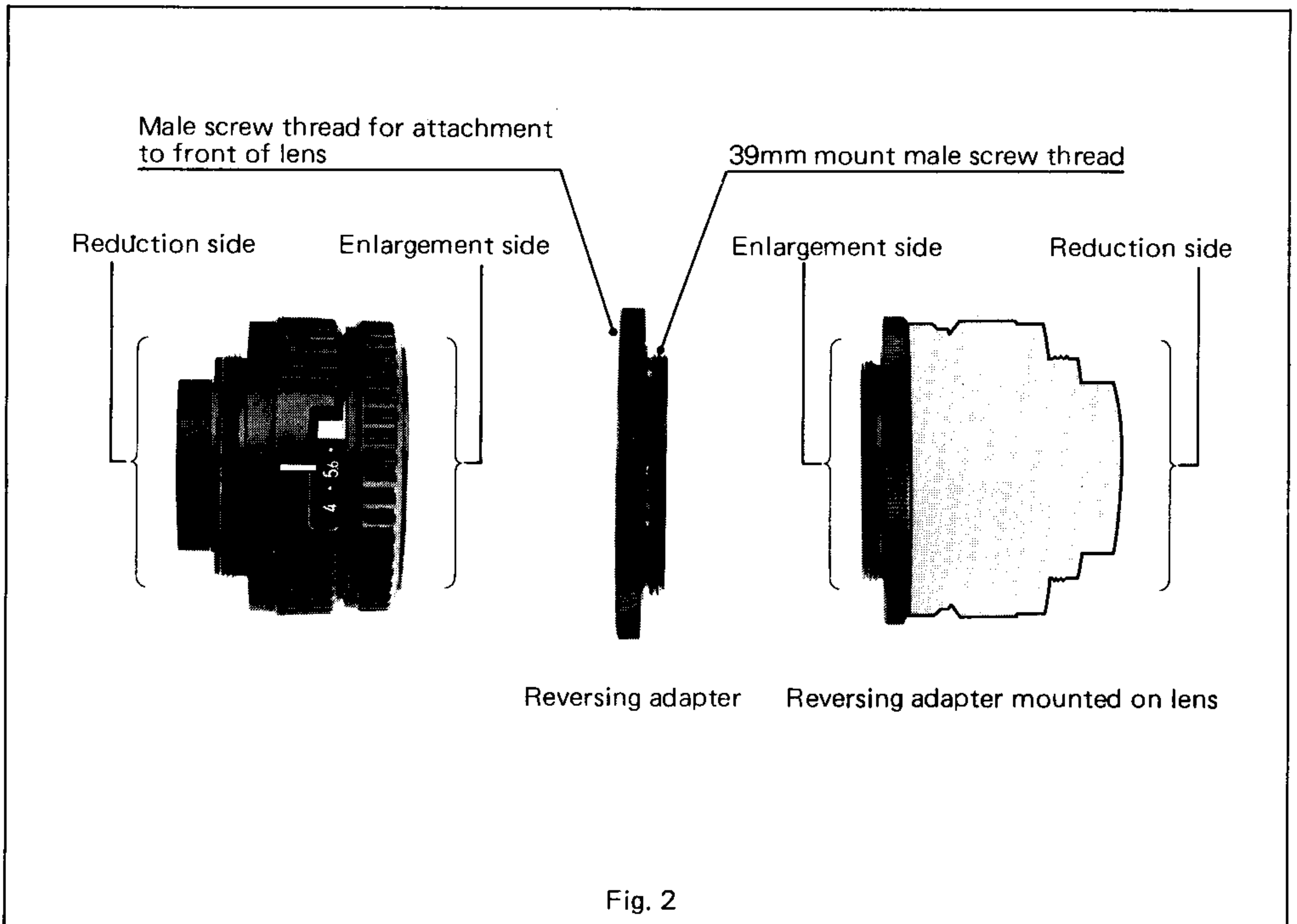

Fig. 2

## Using the lens in the darkroom

For focusing and composing the image on the easel, open up the lens to its maximum aperture of f/2.8. Then just prior to exposure, stop the lens down to f/5.6 or f/8, to ensure maximum corner-to-corner sharpness and the highest possible resolution.

## Tips on lens care

- \* Always keep the lens surfaces clean, as dust or fingerprints can interfere with image sharpness. Use a soft brush—never cloth or tissue—to remove dust. Stubborn smudges should be wiped with lens tissue moistened with alcohol or lens cleaner.
- \* When the lens is removed from the enlarger, store it in its plastic lens case with a desiccant or in a dry place away from the darkroom chemistry.
- \* Darkroom chemicals can cause corrosion or damage to the coating on optical surfaces of the lens. Therefore, if you get chemicals on the lens, clean them off immediately. In severe cases, consult your dealer nearest you.

## Accessories

15mm EL-Extension Ring (optional)  
Reversing adapter for EL 50mm f/2.8, 63mm f/3.5 (optional)

## Specifications

<b>Focal length:</b>	52.1mm
<b>Maximum aperture:</b>	f/2.8
<b>Optical construction:</b>	6 elements in 4 groups
<b>Picture angle:</b>	46°
<b>Aperture scale:</b>	f/2.8–f/16
<b>Corrected wavelength range:</b>	380–700nm
<b>Standard magnification:</b>	8X
<b>Usable magnification range:</b>	2X–20X
<b>Maximum film size:</b>	24mm x 36mm (43.2mm diagonal)
<b>Mount:</b>	39mm screw mount (P = 1/26")
<b>Dimensions:</b>	51mm $\phi$ x 39mm long (overall)
<b>Weight:</b>	105g



This document was archived February 2014 for photomacrography documentation purposes at the <http://extreme-macro.co.uk> extreme macro website. All rights reserved by the document authors.